

MAXIM

MAX1132 Evaluation Kit

General Description

The MAX1132 evaluation system (EV system) is a complete, single-channel data-acquisition system, consisting of a MAX1132 evaluation kit (EV kit) and a Maxim 68HC16MODULE-DIP microcontroller (μ C) module. The MAX1132 is a high-speed, single-channel, 16-bit data acquisition system. Windows[®] 95/98 software provides a handy user interface to exercise the MAX1132's features. Order the complete EV System (MAX1132EVC16) for comprehensive evaluation of the MAX1132 using a PC. Order the EV kit (MAX1132EVKIT) if the 68HC16MODULE-DIP module has already been purchased with a previous Maxim EV system, or for custom use in other μ C-based systems.

The MAX1132 software is designed for use with the complete EV system MAX1132EVC16 (includes 68HC16MODULE-DIP module together with MAX1132 EVKIT). If the MAX1132 evaluation software is not used, the MAX1132EVKIT board can be purchased by itself, without the μ C.

MAX1132EVKIT Parts List

REFERENCE	QTY	DESCRIPTION
C1, C2	2	10 μ F 10V B-size tantalum capacitors
C3	1	2.2 μ F 10V X7R ceramic capacitor
C4	1	0.22 μ F X7R ceramic capacitor (1206)
C5, C6, C8	3	0.1 μ F X7R ceramic capacitors (1206)
C7	1	1 μ F X7R ceramic capacitor (1206)
FB1, FB2	2	Ferrite beads
J1	1	2 x 20 right-angle socket, SamTec SSW-120-02-S-D-RA
JU1, JU5	2	3-pin headers
JU2, JU3, JU4	2	2-pin headers
R1	1	100k Ω \pm 1% 1206 resistor
TB1, TB2	2	0.200in screw terminal blocks
TP1	1	9-pin header
U1	1	MAX1132BCAP
U2	1	74HC04 (14-pin SO) hex inverter
None	1	PC board, MAX1132 EV kit
None	1	3.5in software disk, MAX1132 EV kit
None	1	MAX1132 EV kit data sheet (includes 68HC16MODULE-DIP manual)
None	1	MAX1132 data sheet

Features

- ◆ Proven PC Board Layout
- ◆ Complete Evaluation System
- ◆ Convenient Test Points Provided On-Board
- ◆ Data-Logging Software
- ◆ Fully Assembled and Tested

Ordering Information

PART	TEMP. RANGE	INTERFACE TYPE
MAX1132EVKIT	0°C to +70°C	User supplied
MAX1132EVC16	0°C to +70°C	Windows software

MAX1132EVC16 System Component List

PART	QTY	DESCRIPTION
MAX1132EVKIT	1	MAX1132 EV kit
68HC16MODULE-DIP	1	68HC16 μ C module

List of Files in MAX1132 EV Kit

FILE	DESCRIPTION
INSTALL.EXE	Installs the EV kit files on computer
MAX1132.EXE	Application program
KIT1132.C16	Software loaded into 68HC16 μ C

Windows is a registered trademark of Microsoft Corp.

MAX1132 Evaluation Kit

MAX1132 Stand-Alone EV Kit

The MAX1132EVKIT provides a proven PC board layout to facilitate evaluation of the MAX1132. It must be interfaced to appropriate timing signals for proper operation. Connect +5V to AV_{DD} and connect ground return to AGND (Figure 1). Refer to the MAX1132 data sheet for timing requirements.

MAX1132 EV System

The MAX1132EVC16 EV system operates from a user-supplied +7VDC to +20VDC power supply. Windows 95/98 software running on an IBM PC interfaces to the EV system board through the computer's serial communications port. See the *Quick Start* section for setup and operating instructions.

Quick Start

Recommended Equipment

Before you begin, the following equipment is needed:

- MAX1132EVC16 (contains MAX1132EVKIT board and 68HC16MODULE-DIP)
 - Small DC power supply, such as a 12VDC 0.25A plug-in transformer, or a +9V battery
 - IBM PC-compatible computer running Windows 95/98
 - Spare serial communications port, preferably a 9-pin plug
 - Serial cable to connect the computer's serial port to the 68HC16MODULE-DIP
- 1) Carefully connect the boards by aligning the 40-pin header of the MAX1132 EV kit with the 40-pin connector of the 68HC16MODULE-DIP module. Gently press them together. The two boards should be flush against one another.
 - 2) Check the jumper settings (Table 1).
 - 3) Connect a +7VDC to +20VDC power source to the μ C module at the terminal block located next to the on/off switch, along the top edge of the μ C module. Observe the polarity marked on the board.
 - 4) Connect a cable from the computer's serial port to the μ C module. If using a 9-pin serial port, use a straight-through, 9-pin female-to-male cable. If the only available serial port uses a 25-pin connector, a standard 25-pin to 9-pin adapter is required. The EV kit software checks the modem status lines (CTS, DSR, DCD) to confirm that the correct port has been selected.

- 5) Install the MAX1132 EV kit software on your computer by running the INSTALL.EXE program on the floppy disk. The program files are copied and icons are created for them in the Windows Start menu.
- 6) Start the MAX1132 program by opening its icon in the Start menu.
- 7) The program prompts you to connect the μ C module and turn its power on. Slide SW1 to the ON position. Select the correct serial port and click OK. The program automatically downloads KIT1132.C16 to the module.
- 8) Apply the input signal across the pins of JU2. Observe the readout on the screen.

Detailed Description of Software

The evaluation software main window controls the active control word bits, serial clock speed, and sample rate. It displays the voltage and output code, as well as some statistics of the input signal. A separate graph window shows the data changing in real time. The update rate is limited to about 10 samples per second, due to COM port bandwidth limitations.

Controls

The control word is divided into several fields. To change the active control word, drop down the appropriate field's combo box and select the desired option. If the QSPI clock is set to STOP, the configuration data is not sent until the READ button is clicked.

Statistics

The minimum and maximum fields show the lowest and highest readings acquired. The average and RMS fields show the running mean and root-mean-square of the input signal. The Clear button resets the statistics. To remove offset errors, first apply zero volts to the active input channel, clear statistics, acquire some samples, and then check Tare. This offset is now subtracted from all subsequent voltage measurements.

Sampling

To sample data at rates up to 125ksps, select the Sample menu item, make your selections, and click the Begin Sampling button. Sample size is restricted to a power of two to permit FFT processing once the data is saved to a file. After the samples have been collected, the data is automatically uploaded to the host and is graphed. Once displayed, the data can optionally be saved to a file.

MAX1132 Evaluation Kit

Evaluates: MAX1132/MAX1133

Saving Graphs to Disk

Data in the real-time graph and in sampled data graphs may be saved to a file. Only the raw output codes are saved, but voltages may be inferred based on the reference voltage and the maximum code value.

Evaluating Shutdown

The evaluation software configures the 68HC16's QSPI submodule to continuously read data from the MAX1132 into the 68HC16. The sample rate is controlled by the QSPI clock. To evaluate power-saving modes, these automatic updates must be stopped. First, set the QSPI clock control to STOP. This reconfigures the 68HC16's QSPI submodule to stop driving the serial clock. Second, in the evaluation software's main window, uncheck the Read Every checkbox. Next, choose the desired software power-down control word, and click the Read button to send the new configuration to the MAX1132. If evaluating the hardware shutdown, move JU2 to the 2-3 position.

Reference Voltage

The evaluation software assumes a +4.096V reference voltage and a +12V full-scale voltage, unless otherwise specified. Refer to the MAX1132 data sheet for more information. To override these values, type the new values into the appropriate edit box and click the Set VREF button.

Detailed Description of Hardware

The MAX1132 (U1) is a high-speed, single-channel, 16-bit data-acquisition system. There is no antialiasing filter provided. The input signal may be applied directly to JU2. High-impedance signal sources may require an input buffer, which may be installed in the prototype area. C4 bypasses the bandgap reference, and C3 bypasses the A/D converter's voltage reference. When plugged into the 68HC16MODULE, the AVDD and DVDD circuits are both powered by +5V. (Figure 1). Refer to the MAX1132 data sheet.

Evaluating the MAX1133

To change the evaluation software's full-scale voltage for use with the MAX1133, type 4.096 into the full-scale edit box and click the Set VREF button.

Troubleshooting

Problem: No output measurement. System seems to report zero voltage, or fails to make a measurement.

Check VDD and VLOGIC supply voltages. Check the +4.096V reference voltage using a digital voltmeter. Use an oscilloscope to verify that the conversion-start signal is being strobed. Verify that SHDN is being driven high.

Table 1. Jumper Functions

JUMPER	POSITION	FUNCTION
—	1-2	Operate
JU1	Open	SHDN is controlled by 68HC16 module
—	2-3	Shutdown
JU2	Closed	Measure short circuit (zero volts)
—	Open	Apply input signal at JU2
JU3	Closed	Illegal
—	Open*	Enable internal reference, or apply an external reference
JU4	Closed	Disable internal reference
—	Open*	Enable internal reference
—	1	User-programmable output pin P2
JU5	2	User-programmable output pin P1
—	3	User-programmable output pin P0

*Default configuration

MAX1132 Evaluation Kit

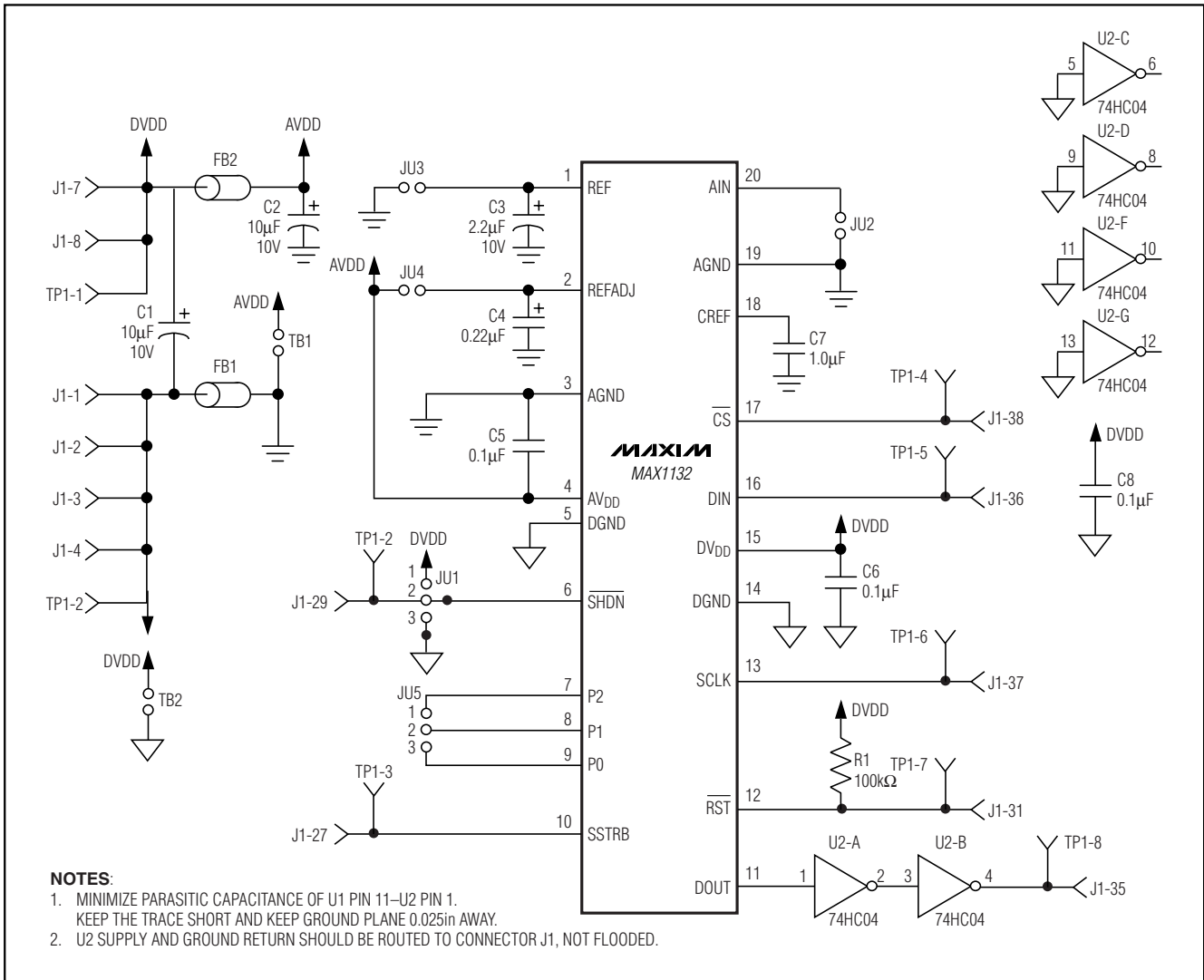

Figure 1. MAX1132 EV Kit Schematic Diagram

Problem: Unacceptable errors when measuring a transducer.

Although most signal sources can be connected directly to the MAX1132's analog input, some high-impedance signal sources may require an input buffer. Check for settling errors by increasing the acquisition time: operate the evaluation kit in external clock mode, 32 clocks per conversion, with the QSPI clock at its slowest setting.

Problem: Measurements are erratic, unstable; poor accuracy.

Check the reference voltage and input using a digital voltmeter. Use an oscilloscope to check for noise. When probing for noise, keep the oscilloscope ground return lead as short as possible, preferably less than 1/2in (10mm).

MAX1132 Evaluation Kit

Evaluates: MAX1132/MAX1133

```
Init: LDAA #$08          ; CS high, clock low by default
      STAA QPDR
      LDAA #$0F
      STAA QPAR          ; pins that are assigned to the QSPI
      LDAA #$0E
      STAA QDDR          ; QSM pins that are outputs
      LDAA #$80          ; CRCONT
      STAA CR0           ; send eight-bit control word, and continue...
      STAA CR2
      STAA CR4
      ...
      STAA CRE
      LDAA #$40          ; (CRBITSE)
      STAA CR1           ; receive sixteen-bit data field
      STAA CR3
      STAA CR5
      ...
      STAA CRF
      CLR D              ; send zero when receiving data
      STD TR1
      STD TR3
      STD TR5
      ...
      STD TRF
      LDAB #%10001111    ; channel 0, unipolar, single-ended, pd=11
      std TR0            ; channel 0 command
      ldab #$40          ; channel 1 bit mask
      ord TR0
      std TR2            ; channel 1 command
      ldab #$10          ; channel 2 bit mask
      ord TR0
      std TR4            ; channel 2 command
      ...
      ldab #$70          ; channel 7 bit mask
      ord TR0
      std TRE            ; channel 7 command
      CLR SPCR3          ; disable QSPI halt mode interrupt
      LDD #$8008         ; BITS=16, SPBR=8 (1.049 MHz), CPOL=0, CPHA=0
      STD SPCR0
      LDD #$0204         ; DSCCK, DTL not used
      STD SPCR1
      LDD #$4F00         ; newqp=0, endqp=15, wrap to zero
      STD SPCR2          ; run QSPI continuously on all channels
      BSETW SPCR1,$$8000 ; start the QSPI
      BCLR SPSR,$$80     ; clear SPIF bit
ReadLoop:
      LDD RR1
      jsr Process_Channel_0
      LDD RR3
      jsr Process_Channel_1
      LDD RR5
      jsr Process_Channel_2
      ...
      LDD RRF
      jsr Process_Channel_7
      jmp ReadLoop
```

Listing 1. Reading All Channels with QSPI

MAX1132 Evaluation Kit

```
Init: LDAA #$08          ; CS high, clock low by default
      STAA QPDR
      LDAA #$0F
      STAA QPAR          ; pins that are assigned to the QSPI
      LDAA #$0E
      STAA QDDR          ; QSM pins that are outputs
      LDAA #$80          ; CRCONT
      STAA CR0           ; send eight-bit control word, and continue...
      LDAA #$40          ; (CRBITSE)
      STAA CR1           ; receive sixteen-bit data field
      CLRD               ; send zero when receiving data
      STD  TR1
      LDAB #%10001111    ; channel 0, unipolar, single-ended, pd=11
      std  TR0           ; channel 0 command
      CLR  SPCR3         ; disable QSPI halt mode interrupt
      LDD  #$8008        ; BITS=16, SPBR=8 (1.049 MHz), CPOL=0, CPHA=0
      STD  SPCR0
      LDD  #$0204        ; DSCK, DTL not used
      STD  SPCR1
      LDD  #$0100        ; newqp=0, endqp=1, no wrap
      STD  SPCR2

ReadLoop:
      BSETW SPCR1,$#8000 ; start the QSPI
      BCLR  SPSR,$#80    ; clear SPIF bit
Idle: BRCLR SPSR,$#80,Idle ; wait until SPIF bit is set
      LDD  RR1
      ROLD
      ROLD
      ROLD
      jsr  Process_Channel_0
      jmp  ReadLoop
```

Listing 2. Reading a Single Channel with QSPI

MAX1132 Evaluation Kit

Evaluates: MAX1132/MAX1133

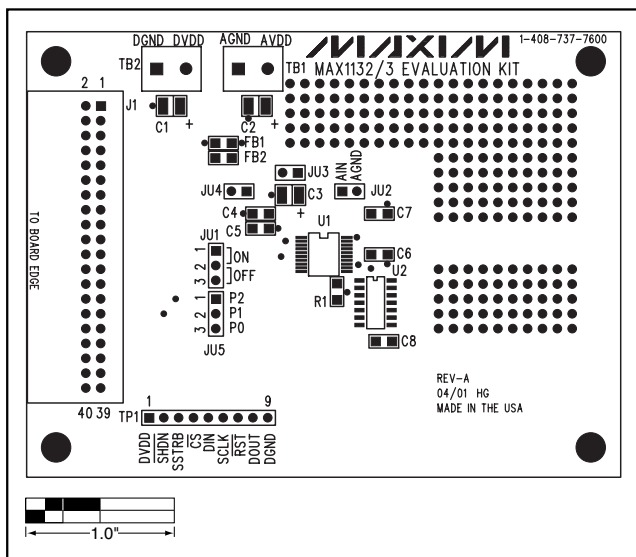

Figure 2. MAX1132 EV Kit Component Placement Guide — Component Side

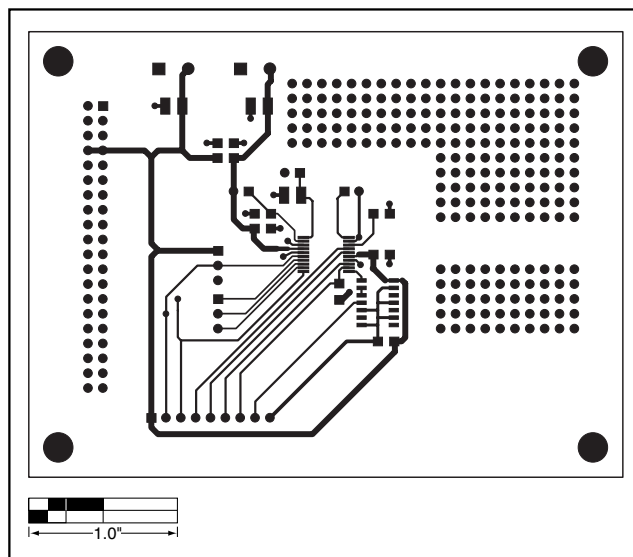

Figure 3. MAX1132 EV Kit PC Board Layout—Component Side

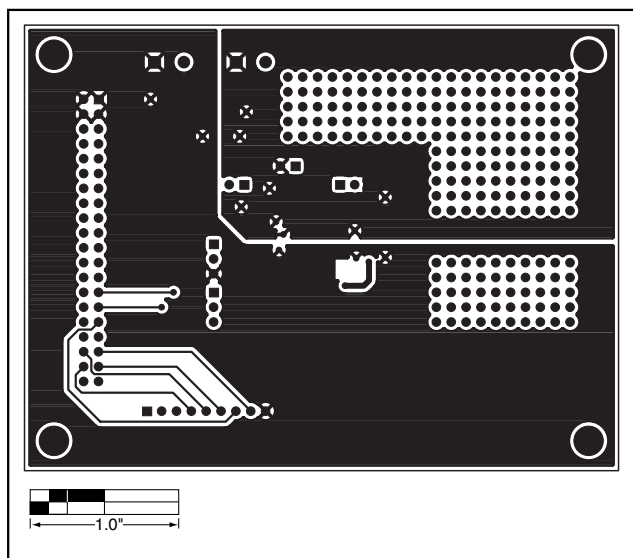

Figure 4. MAX1132 EV Kit PC Board Layout—Solder Side

Maxim cannot assume responsibility for use of any circuitry other than circuitry entirely embodied in a Maxim product. No circuit patent licenses are implied. Maxim reserves the right to change the circuitry and specifications without notice at any time.

Maxim Integrated Products, 120 San Gabriel Drive, Sunnyvale, CA 94086 408-737-7600 _____ 7